

PRPOWER

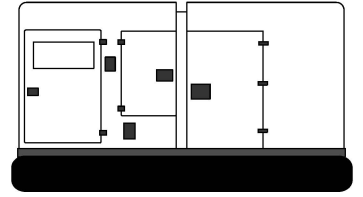

Generator set Sound-proof type PR1375P-SAE

SPECIFICATIONS

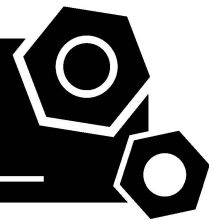

www.prpower.com | 1300 399 499

PR Power reserves the right to make changes in model, technical specification, color, configuration and accessories without prior notice. Please contact the sales team before ordering.

Rev. [July].[2023]

1 Standards & Conditions

Design Standards

The designs and the productions are in conformity with:

- Conformance Européenne (CE)
- ISO8528-5:2005
- AS 3000-2018
- AS 3010-2017

Environmental Operating Conditions

- Installation place: Outdoors or indoors (well ventilated).
- Ambient temperature: -25°C to 50°C. The coolant heater is needed when the temperature is below 5°C
- Humidity: Less than 80%.
- Altitude: Below one thousand (1000) meters above sea Level.

Factory Inspection

- Inspection items.
- Protection devices working test.
- Starting ability in normal temperature.
- 50% rated power load moment capability.
- Voltage deviation and speed variation: 0%, 25%, 50%, 75%, 100%, 110% Load.

Painting Process

- Painting process specifications and colors are based on the manufacturer's standard.
- The customer could also choose the color which the manufacturer offers.

2 General Features

- Perkins engine 4012-46TWG2A
- Close coupled to LSA alternator LSA50.2M6
- Microprocessor control module PLC-7420
- ABB main circuit breaker: 2000A
- Rotate speed governor: Electronic governor
- Excitation system: AREP
- A.V.R. Model: R450
- Key switch
- Emergency stop switch
- ATS (automatic transfer switch) receptacle
- 4x12V/150AH sealed for life maintenance free battery

- Lockable battery isolator switch
- Powder coated canopy
- Standard container
- 50 °C radiator
- Fire extinguisher
- Oil pump on the engine
- Vibration isolators between the engine/alternator and base frame
- Dry type air filter
- Fuel tank with 4 hours running
- Drain points for fuel tank
- Fuel-water separator for fuel tank
- Operation Manual / Specification

3 Equipment Specification

General technical data

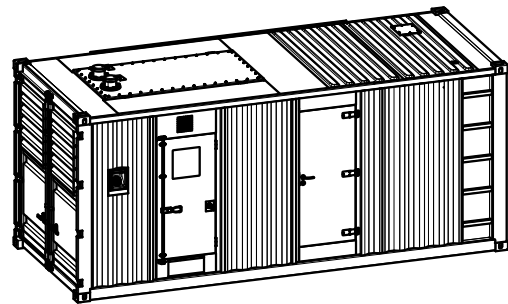

Model.....	PR1375P-SAE
Structure type	C
Tank capacity.....	1150L
Dry weight.....	15500kg
Noise level @7m	79.2dBA
Dimensions L×W×H.....	6058x2438x2591mm
Standby Power	1375kVA/1100kW
Prime Power.....	1250kVA/1000kW

Voltage	380V	400V	415V	440V	
Ampere	1899A	1804A	1739A	1640A	
Genset Fuel Consumption					
Frequency/Load	25%	50%	75%	100%	110%
50Hz (L/h)	65.5	131.1	196.6	262.2	288.8

Dck Yf 'GrghYa

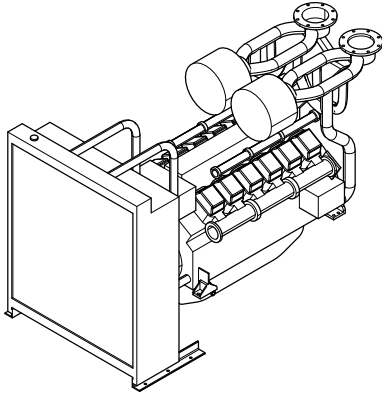

Engine Manufacturer/Brand.....	Perkins
Engine Model.....	4012-46TWG2A
Dimensions L×W×H.....	3714×1978×2255mm
Dry Weigh (approx.).....	5283kg
Number of Cylinders.....	12
Bore.....	160mm
Stroke.....	190mm
Displacement.....	45.48L
Compression Ratio.....	13.6
Type of Injection.....	Direct injection
Intake System.....	Turbocharged
Intake Resistance.....	≤4kPa
Cooling System.....	Water cooled
Fan.....	Pusher
Battery Voltage.....	24V
Type of Fuel.....	BS2869 1998 class A2 or BS EN590
Type of Oil.....	15W40
Oil Capacity.....	177L
Type of Coolant.....	Glycol mixture
Coolant capacity.....	201L
Back Pressure.....	≤5kPa
Standby Power.....	1224kW
Prime Power.....	1113kW
Fuel Consumption(100%load).....	212g/kW.h

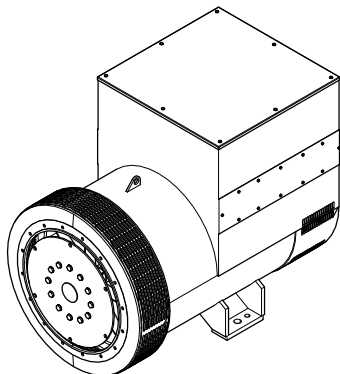

Alternator Manufacturer/Brand.....	Leroy Somer
Alternator Model.....	LSA50.2M6
Exciter.....	Brushless
Cooling Fan.....	Cast alloy aluminum
Windings.....	100% copper
Insulation Class.....	H
Winding Pitch.....	2/3
Terminals.....	6
Drip Proof.....	IP23
Altitude.....	≤1000m
Overspeed.....	2250rpm
Air Flow.....	1.8m³/s(50Hz),2.2m³/s(60Hz)
Voltage Regulation.....	±0.5%
Total harmonic TGH / THC.....	< 3.5%
Telephone Interference.....	THF<2%;TIF<50

PLC-7420 Control System

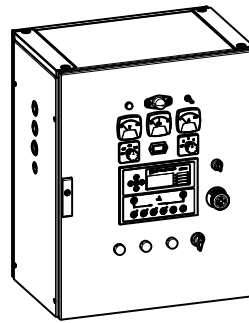

PLC-7420 is an advanced control module based on micro-processor, containing all necessary functions for protection of the genset and the breaker control. It can monitor the mains supply, and automatically start the engine when the mains is abnormal. Accurately measure various operational parameters and display all values and alarms information on the LCD. In addition, the control module can automatically shut down the engine and indicate the engine failure.

- Microprocessor control, with high stability and credibility
- Monitoring and measuring operational parameters of the mains supply and genset
- Indicating operation status, fault conditions, all parameters and alarms
- Multiple protections; multiple parameters display, like pressure, temp. etc.
- Manual, automatic and remote work mode selectable
- Real time clock for time and date display, overall runtime display, 250 log entries
- Overall power output display
- Integral speed/frequency detecting, telling status of start, rated operation, overspeed etc.
- Communication with PC via RS485 OR RS232 interface, using MODBUS protocol

4 Overall Dimensions

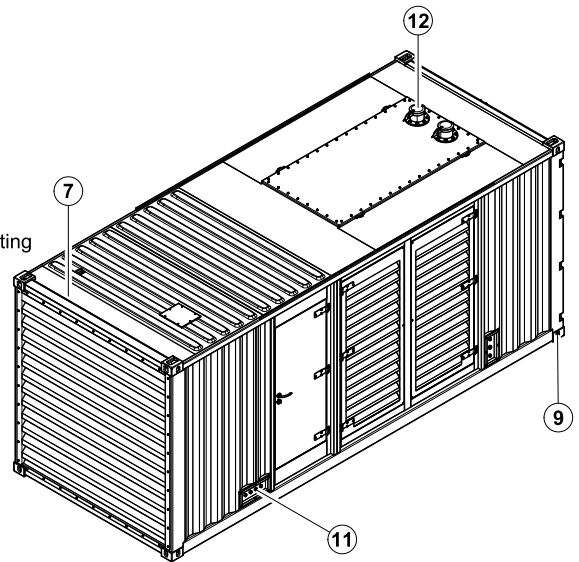
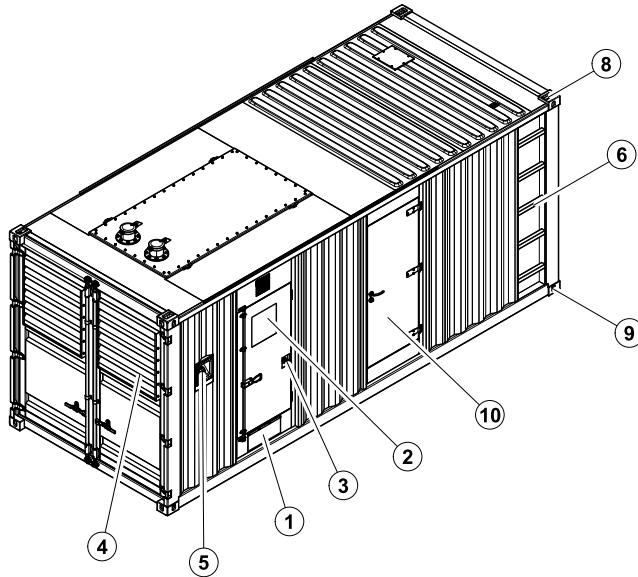

- | | |
|-------------------------|---|
| ⑥ Ladder | ⑫ Exhaust gas outlet |
| ⑤ Fuel inlet | ⑪ External fuel inlet/Return hose fitting
Coolant/Oil drain hose fitting |
| ④ Air inlet | ⑩ Access door |
| ③ Emergency stop switch | ⑨ Fixing lug |
| ② Control cabinet | ⑧ Lifting lug |
| ① Cable trench | ⑦ Canopy |

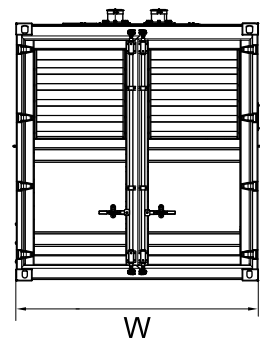
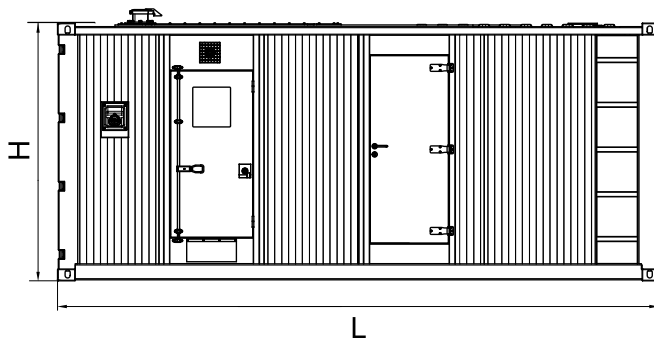

5 Control System

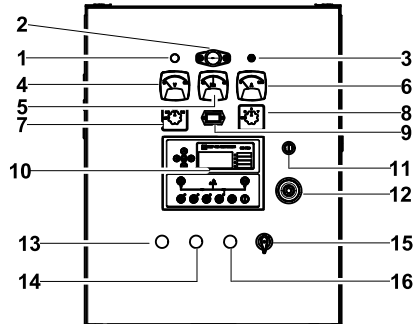

Control cabinet

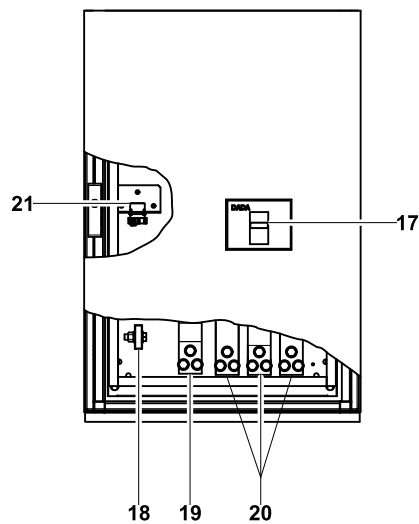

Field wiring cabinet

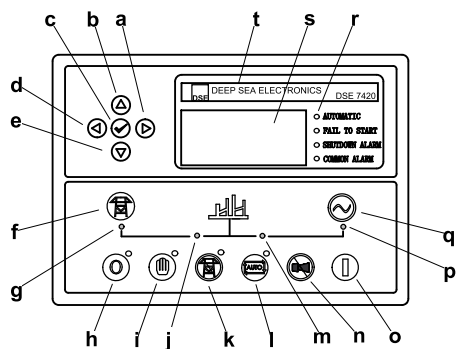

Control module

Ref.	Description
1	Charge indicator
2	Control cabinet lamp
3	Control cabinet lamp switch
4	Voltage meter
5	Frequency meter
6	Current meter
7	Changerover switch-Voltage
8	Changerover switch-Current
9	Time counter
10	Control module
11	Key switch
12	Emergency stop switch
13	Fuel leak indicator
14	Running button with indicator
15	Oil drain switch
16	Stop button with indicator
17	Main circuit breaker
18	Ground wire terminal
19	Neutral wire terminal
20	Live wire terminals
21	Mains input/Remote control/ ATS communication connector

a	Button (next page)
b	Button (increase value / previous item)
c	Button (accept)
d	Button (previous page)
e	Button (decrease value / next item)
f	Button (transfer the load to the mains supply, when in Manual mode only)
g	Mains supply available LED
h	Stop / Reset button
i	Manual button (Manual control mode)
j	Mains supply on load LED
k	Test button (Test mode)
l	Auto button (Auto mode)
m	Genset on load LED
n	Mute/Lamp test button
o	Start button (Manual)
p	Genset available LED
q	Button (transfer the load to the genset, when in Manual mode only)
r	Alarm LED (4 alarm items)
s	LCD display
t	Control module name