

**Generator set
Sound-proof type
PR220P-SAE**

SPECIFICATIONS

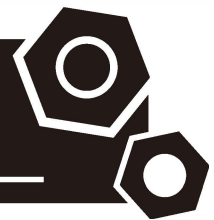

www.prpower.com | 1300 399 499

PR Power reserves the right to make changes in model, technical specification, color, configuration and accessories without prior notice. Please contact the sales team before ordering.

Rev. [July].[2023]

1 Standards & Conditions

Design Standards

The designs and the productions are in conformity with:

- Conformance Européenne (CE)
- ISO8528-5:2005
- AS 3000-2018
- AS 3010-2017

Environmental Operating Conditions

- Installation place: Outdoors or indoors (well ventilated).
- Ambient temperature: -25°C to 50°C. The coolant heater is needed when the temperature is below 5°C
- Humidity: Less than 90%.
- Altitude: Below one thousand (1000) meters above sea level.

Factory Inspection

- Inspection items.
- Protection devices working test.
- Starting ability in normal temperature.
- 50% rated power load moment capability.
- Voltage deviation and speed variation: 0%, 25%, 50%, 75%, 100%, 110% Load.

Painting Process

- Painting process specifications and colors are based on the manufacturer's standard.
- The customer could also choose the color which the manufacturer offers.

2 General Features

- Perkins engine 1106A-70TAG4
- Close coupled to a LS alternator LSA44.3VL14
- Microprocessor control module PLC-7420
- ABB main circuit breaker: 320A
- Rotate speed governor: Mechanical governor
- Excitation System: Self Excited,SHUNT
- A.V.R.Model: R250
- Key switch
- Emergency stop switch
- ATS (automatic transfer switch) receptacle

- Remote run connector
- 1x12V/120AH sealed for life maintenance free battery
- Lockable battery isolator switch
- Powder coated canopy
- 50°C radiator
- Oil pump on the engine
- Non-returning valve for fuel inlet hose of the engine
- Steel base frame with forklots
- Vibration isolators between the engine/alternator and base frame
- Dry type air filter
- Base fuel tank with 24 hours running
- Drain points for fuel tank
- Breather valve for fuel tank
- Operation Manual / Specifications

3 Equipment Specification

General technical data

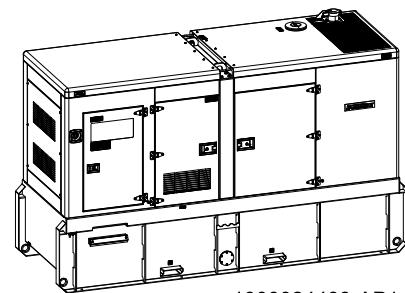

1000024483-AP1-D2

Model.....	PR200P-SAE
Structure type	R
Tank capacity	1087L
Dry weight.....	2827kg
Noise level @7m	74.2dBA
Dimensions L×W×H.....	3468x1142x2088mm
Standby Power	220kVA/176kW
Prime Power	200kVA/160kW
Voltage/Ampere	415V/278.2A

Genset Fuel Consumption					
Frequency/Load	25%	50%	75%	100%	110%
50Hz (L/h)	N/A	25	36	45.8	49.4

Diesel Engine

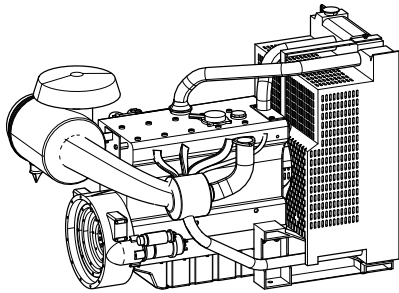

1000152213-AP1-A2

Engine Manufacturer/Brand	Perkins
Engine Model	1106A-E70TAG4
Dimensions L×W×H	1763×756×1142mm
Dry Weight (approx.)	788kg
Number of Cylinders	6
Bore	105mm
Stroke	135mm
Displacement	7.01L
Compression Ratio	16
Type of Injection	Direct injection
Intake System	Turbocharged and air charge cooled
Intake Resistance	≤8kPa
Cooling System	Water cooled
Fan	Pusher
Battery Voltage	12V
Type of Fuel	ASTM D975, Class 1D & Class 2D
Type of Oil	API-CH4/ACEA E5
Oil Capacity	16.5L
Type of Coolant	Glycol mixture
Coolant Capacity	21L
Heat Rejected To Exhaust System ...	148kW(8288BTU/min)
Heat Rejected To Water&Oil	78kW(4368BTU/min)
Back Pressure	≤15kPa
Standby Power	176kW
Prime Power	160kW
Fuel Consumption(100%load)	45.8L/h

Alternator

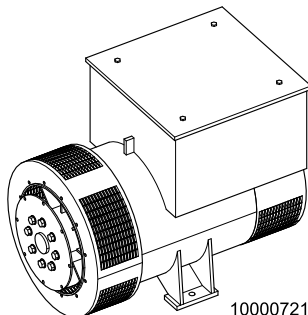

1000072129-AP1-A1

Alternator Manufacturer/Brand	Leroy Somer
Alternator Model	LSA44.3VL14
Exciter	Brushless
Cooling Fan	Cast alloy aluminum
Windings	100% copper
Insulation Class	H
Winding Pitch	2/3
Terminals	12
Drip Proof	IP23
Altitude	≤1000m
Overspeed	2250rpm
Air Flow	0.43m³/s(50Hz),0.51m³/s(60Hz)
Voltage Regulation	±0.5%
Total harmonic TGH / THC	at no load < 2.5 % - on load < 2.5%
Telephone Interference	THF<2%;TIF<50

PLC-7420 Control System

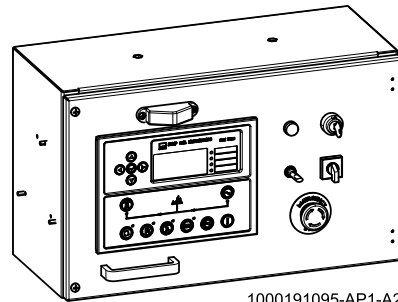

1000191095-AP1-A2

PLC-7420 is an advanced control module based on micro-processor, containing all necessary functions for protection of the genset and the breaker control. It can monitor the mains supply, and automatically start the engine when the mains is abnormal. Accurately measure various operational parameters and display all values and alarms information on the LCD. In addition, the control module can automatically shut down the engine and indicate the engine failure.

- Microprocessor control, with high stability and credibility
- Monitoring and measuring operational parameters of the mains supply and genset
- Indicating operation status, fault conditions, all parameters and alarms
- Multiple protections; multiple parameters display, like pressure, temp. etc.
- Manual, automatic and remote work mode selectable
- Real time clock for time and date display, overall runtime display, 250 log entries
- Overall power output display
- Integral speed/frequency detecting, telling status of start, rated operation, overspeed etc.
- Communication with PC via RS485 OR RS232 interface, using MODBUS protocol

4 Overall Dimensions

1000024483-DR1-D2

Dry weight	2976kg
Fuel tank capacity	1087L
Dimensions L x W x H	3518x1222x2153mm

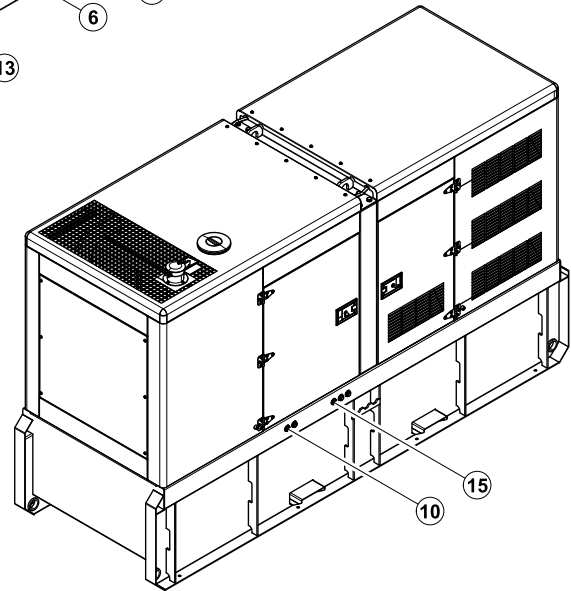
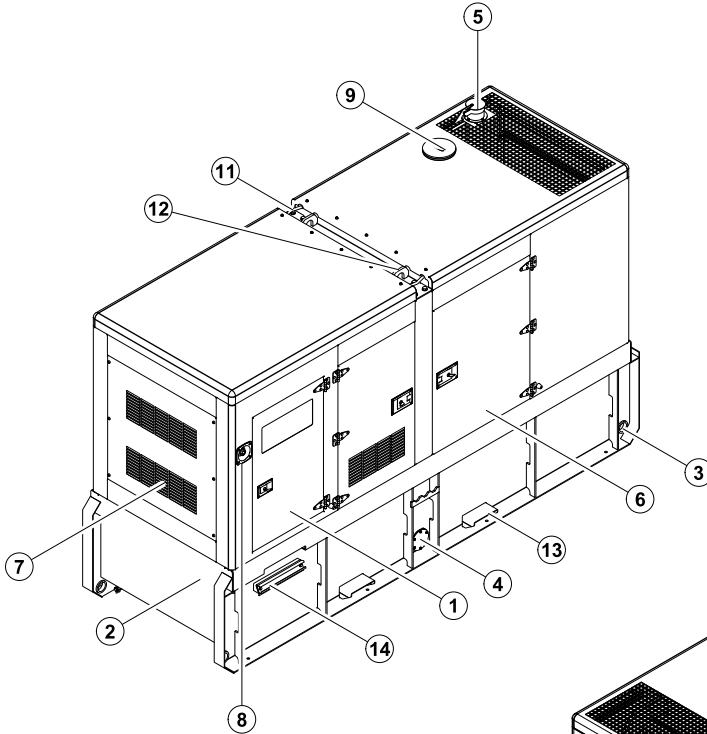

- ⑧ Emergency stop switch
- ⑦ Air inlet
- ⑥ Access door
- ⑤ Exhaust gas outlet
- ④ Fuel drain
- ③ Tie down
- ② Base frame
- ① Control cabinet
- ⑮ Coolant/Oil drain hose fitting
- ⑭ Cable trench
- ⑬ Fork lift channel
- ⑫ Lifting lug
- ⑪ Roping lug
- ⑩ External fuel inlet/return hose fitting
- ⑨ Coolant inlet

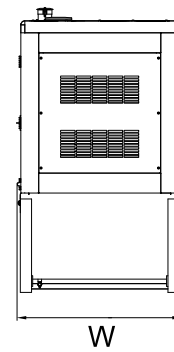
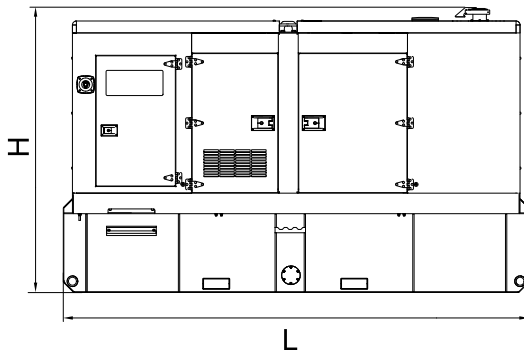

5 Control System

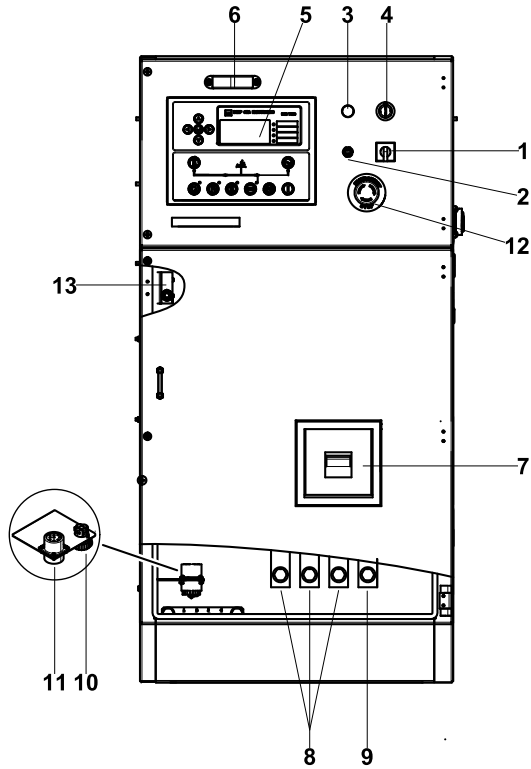

Control & Field wiring cabinet

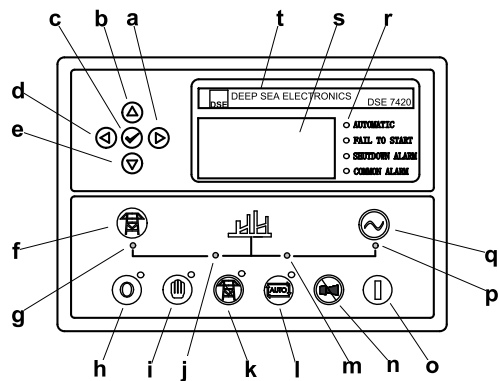

Control module

Ref.	Description
1	Mains input changeover switch
2	Control cabinet lamp switch
3	Charge indicator
4	Key switch
5	Control module
6	Control cabinet lamp
7	Main circuit breaker
8	Live wire terminals
9	Neutral wire terminal
10	Mains input/Remote control communication connector
11	Mains input/Remote control/ATS communication connector
12	Emergency stop switch
13	Limit switch

a	Button (next page)
b	Button (increase value / previous item)
c	Button (accept)
d	Button (previous page)
e	Button (decrease value / next item)
f	Button (transfer the load to the mains supply, when in Manual mode only)
g	Mains supply available LED
h	Stop / Reset button
i	Manual button (Manual control mode)
j	Mains supply on load LED
k	Test button (Test mode)
l	Auto button (Auto mode)
m	Genset on load LED
n	Mute/Lamp test button
o	Start button (Manual)
p	Genset available LED
q	Button (transfer the load to the genset, when in Manual mode only)
r	Alarm LED (4 alarm items)
s	LCD display
t	Control module name