

Generator set
Sound-proof type
PR17P-SAE

SPECIFICATIONS

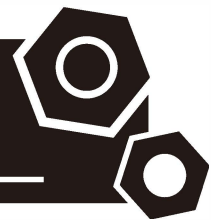

www.prpower.com | 1300 399 499
PR Power reserves the right to make changes in model, technical specification, color, configuration and accessories without prior notice. Please contact the sales team before ordering.
Rev. [July].[2023]

1 Standards & Conditions

Design Standards

The designs and the productions are in conformity with:

- Conformance Européenne (CE)
- ISO8528-5:2005
- AS 3000-2018
- AS 3010-2017

Environmental Operating Conditions

- Installation place: Outdoors or indoors (well ventilated).
- Ambient temperature: -25°C to 45°C. The coolant heater is needed when the temperature is below 5°C
- Humidity: Less than 80%.
- Altitude: Below one thousand (1000) meters.

Factory Inspection

- Inspection items.
- Protection devices working test.
- Starting ability in normal temperature.
- 50% rated power load moment capability.
- Voltage deviation and speed variation: 0%, 25%, 50%, 75%, 100%, 110% Load.

Painting Process

- Painting process specifications and colors are based on the manufacturer's standard.
- The customer could also choose the color which the manufacturer offers.

2 General Features

- Perkins engine 403A-15G2
- Close coupled to LSA alternator LSA40S3
- Microprocessor control module PLC-920
- SCHNEIDER main circuit breaker: 32A
- Rotate speed governor: Mechanical governor
- Excitation system: Self excited,SHUNT
- A.V.R model: R250
- Key switch
- ATS (automatic transfer switch) receptacle
- 3x Convenience receptacles
- 1x12V/72AH sealed for life maintenance free battery

- Lockable battery isolator switch
- Powder coated canopy
- 50°C radiator
- Oil pump on the engine
- Steel base frame with lifting lugs
- Vibration isolators between the engine/alternator and base frame
- Dry type air filter
- Base fuel tank for 24 hours running
- Drain points for fuel tank
- Operation Manual / Specifications

3 Equipment Specification

General technical data

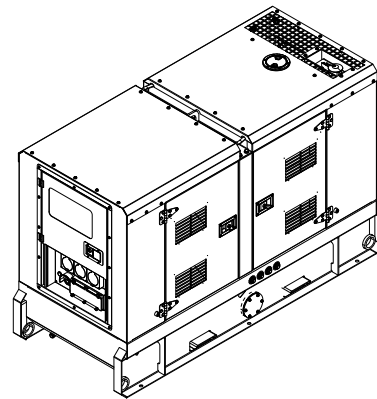

Model.....	PR17P-SAE
Structure type	RS
Tank capacity.....	100L
Dry weight.....	731kg
Noise level @7m	66.7dBA
Dimensions L×W×H.....	1932x878x1208mm
Standby Power	17kVA/13kW
Prime Power	15kVA/12kW

Voltage	380V	400V	415V	440V	
Ampere	22.8A	21.6A	20.8A	19.7A	
Genset Fuel Consumption					
Frequency/Load	25%	50%	75%	100%	110%
50Hz (L/h)	2.5	3.1	3.6	4.1	4.9

Diesel engine

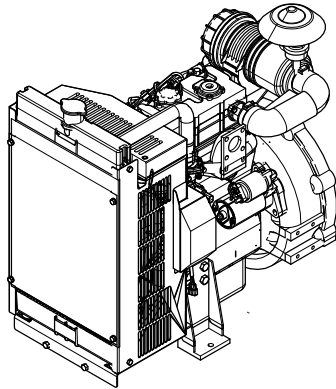

Engine Manufacturer/Brand.....	Perkins
Engine Model.....	403A-15G2
Dimensions L×W×H.....	820×469×793mm
Dry Weigh (approx.)	197kg
Number of Cylinders.....	3
Bore.....	84mm
Stroke.....	90mm
Displacement.....	1.496L
Compression Ratio.....	22.5
Type of Injection	Indirect injection
Intake System.....	Natural aspirated
Intake Resistance.....	≤6.4kPa
Cooling System	Water cooled
Fan	Pusher
Battery Voltage.....	12V
Type of Fuel.....	EPA2D 89.330-96/CEC RF-06-99
Type of Oil	API-CH-4/ ACEA E5
Oil Capacity	6.0L
Type of Coolant	Glycol mixture
Coolant Capacity.....	6.0L
Back Pressure.....	≤10.2kPa
Standby Power.....	16kW
Prime Power.....	14kW
Fuel Consumption(100%load).....	4.1L/h

Alternator

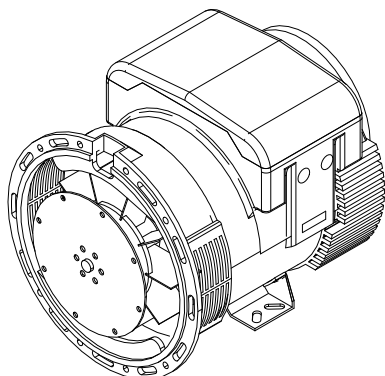

Alternator Manufacturer/Brand	Leroy Somer
Alternator Model	LSA40S3
Exciter.....	Brushless
Cooling Fan	Cast alloy aluminum
Windings.....	100% copper
Insulation Class	H
Winding Pitch.....	2/3
Terminals	12
Drip Proof	IP23
Altitude.....	≤1000m
Overspeed	2250rpm
Air Flow.....	5.3m³/min(50Hz),5.8m³/min(60Hz)
Voltage Regulation	±1.0%
Total harmonic TGH / THCat no load < 1.5 % - on load < 5%	
Telephone Interference.....	THF<2%;TIF<45

PLC-920 Control System

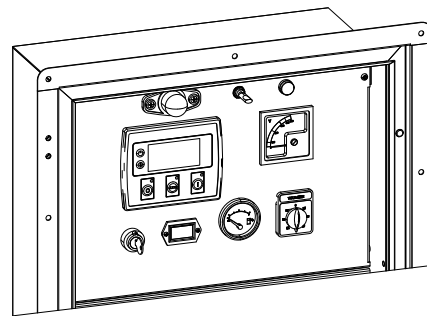

PLC-920 is an advanced control module based on micro-processor designed to control the engine via a key switch and push buttons on the front panel. The module is used to start and stop the engine and indicate fault conditions, automatically shutting down the engine and giving a true first up fault condition of an engine failure.

Standard Control Function

- Manual Engine Control Module
- Low Oil Pressure
- High Engine Temperature
- Auxiliary Shutdown
- Overspeed Protection
- Protection hold-off timer
- Charge Failure warning

4 Overall Dimensions

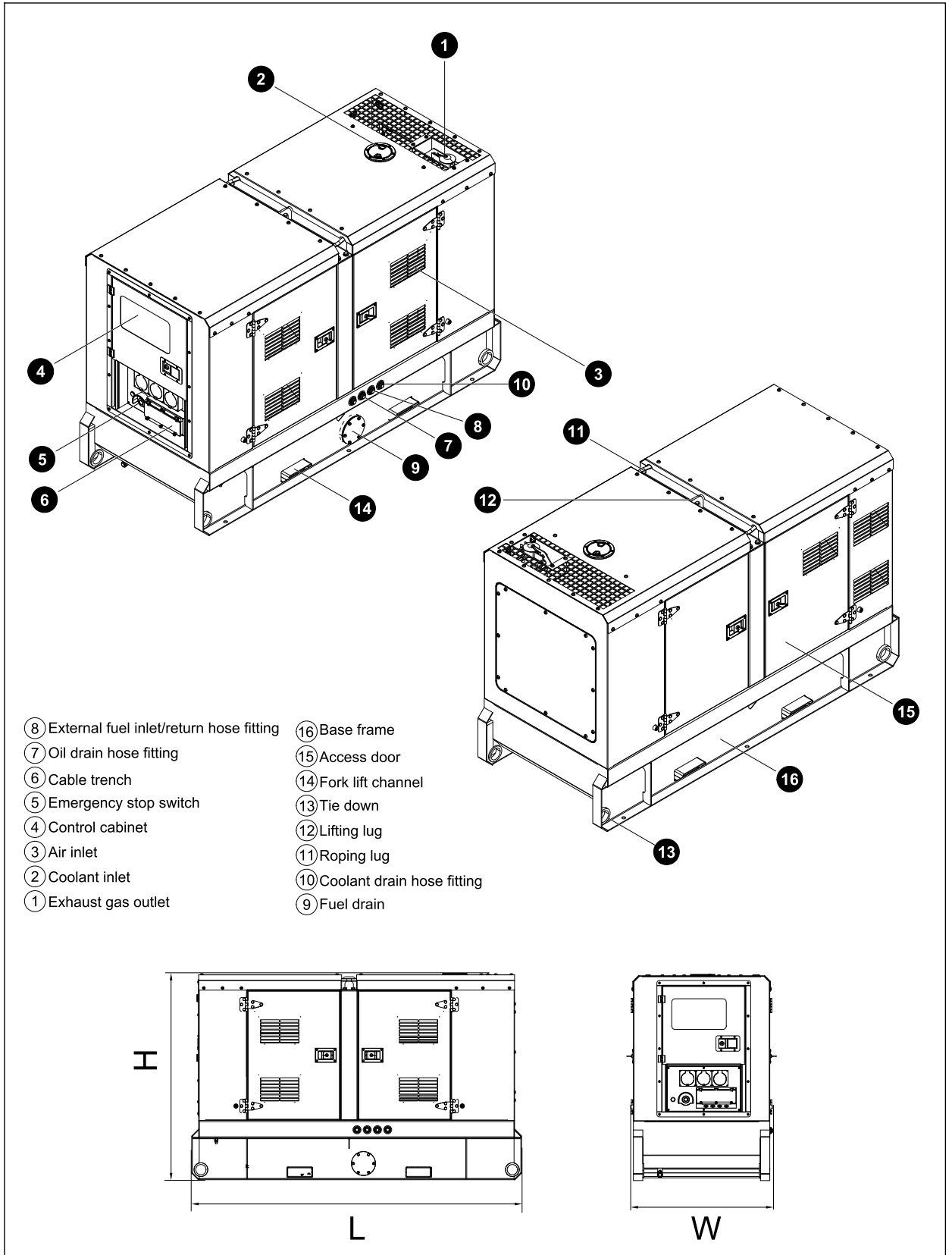

5 Control System

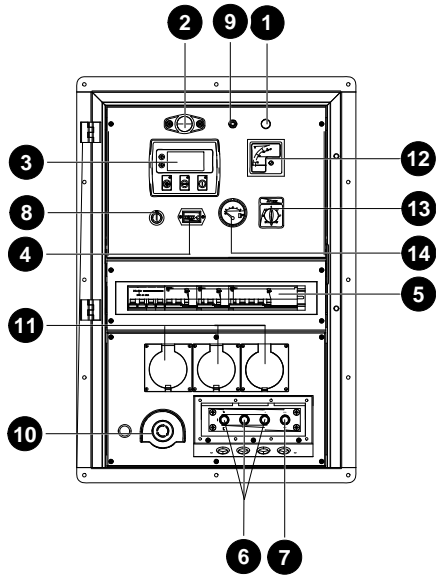

Control & field wiring cabinet

Ref.	Description
1	Indicator
2	Control cabinet lamp
3	Control module
4	Time counter
5	Main circuit breaker
6	Live wire terminals
7	Neutral wire terminal
8	Key switch
9	Control cabinet lamp switch
10	Emergency stop switch
11	3x Convenience receptacles
12	Voltmeter
13	Voltage change-over switch
14	Fuel level meter

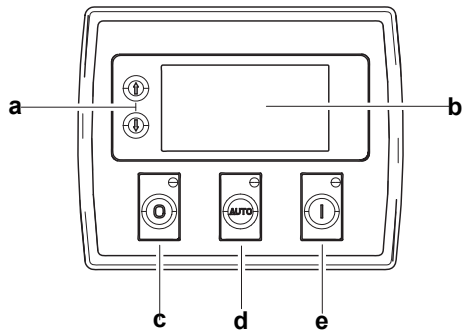

Control module

Ref.	Description
a	Navigation button£» Accept (Configuration mode only)
b	Main status display
c	Stop/reset button£» Next page (Configuration mode only)
d	Auto start button£» Decrease value/next item (Configuration mode only)
e	Start button£» Increase value/next item (Configuration mode only)